

Tektronix[®]
COMMITTED TO EXCELLENCE

010-6056-03

**P6056/P6057
PROBE**

INSTRUCTION MANUAL

Tektronix, Inc.
P.O. Box 500
Beaverton, Oregon 97077

Serial Number _____

Copyright © 1971 Tektronix, Inc. All rights reserved.
Contents of this publication may not be reproduced in
any form without the written permission of Tektronix, Inc.

Products of Tektronix, Inc. and its subsidiaries are
covered by U.S. and foreign patents and/or pending
patents.

TEKTRONIX, TEK, SCOPE-MOBILE, and  are
registered trademarks of Tektronix, Inc. TELEQUIP-
MENT is a registered trademark of Tektronix U.K.
Limited.

Printed in U.S.A. Specification and price change
privileges are reserved.

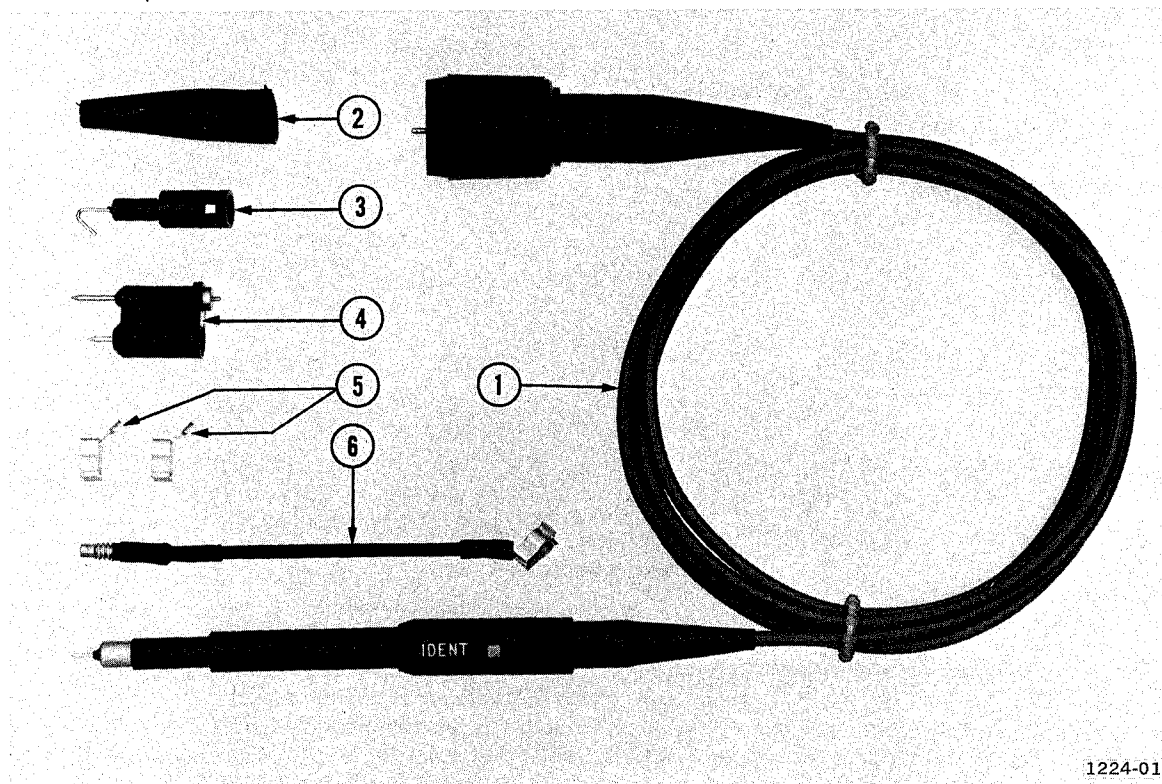

Fig. 1. P6056/P6057 probe with standard accessories.

1224-01

Fig. & Index No.	Tektronix Part No.	Serial/Model No. Eff Dscont	Qty	1	2	3	4	5	Name & Description	Mfr Code	Mfr Part Number
PROBE PACKAGE											
	010-6056-03		1						PROBE, VOLTAGE: 72.0 L, 10X, W/ACCESS	80009	010-6056-03
	010-6056-05		1						PROBE, VOLTAGE: 108.0 L, 10X, W/ACCESS	80009	010-6056-05
	010-6057-03		1						PROBE, VOLTAGE: 72.0 L, 100X, W/ACCESS	80009	010-6057-03
	010-6057-05		1						PROBE, VOLTAGE: 108.0 L, 100X, W/ACCESS	80009	010-6057-05
	-----		-						. PROBE PACKAGE INCLUDES:		
PROBE ONLY											
-1	010-6056-02		1						PROBE, VOLTAGE: 72.0 L, 10X	80009	010-6056-02
	010-6056-04		1						PROBE, VOLTAGE: 108.0 L, 10X	80009	010-6056-04
	010-6057-02		1						PROBE, VOLTAGE: 72.0 L, 100X	80009	010-6057-02
	010-6057-04		1						PROBE, VOLTAGE: 108.0 L, 100X	80009	010-6057-04
STANDARD ACCESSORIES											
-2	344-0046-00		1						CLIP, ELECTRICAL: ALLIGATOR TYPE, W/COVER	80009	344-0046-00
-3	206-0114-00		1						TIP, PROBE: HOOK	80009	206-0114-00
-4	013-0085-00		1						TIP, PROBE: GROUNDING	80009	013-0085-00
-5	214-0283-00		2						CONTACT, ELEC: GND SPRING, 0.270" L, COPPER	80009	214-0283-00
-6	175-0249-00		1						LEAD, ELECTRICAL: STRD, 23 AWG, 3.0 L	80009	175-0249-00
	175-0849-01	X7250	1						LEAD, ELECTRICAL: STRD, 18 AWG, 5.25 L	80009	175-0849-01
R1	307-0330-00	X7943	1						RES., FXD, FILM: ASSY 400 OHM, 1%, 0.5W	03888	OBD
	-----		-						(P6056 ONLY)		
R1	307-0329-00	X7943	1						RES., FXD, FILM: 4.9K OHM, 1%, 0.5W	03888	OBD
	-----		-						(P6057 ONLY)		

WARNING

This high performance device has a fragile resistor assembly in the probe head, subject to failure in rough usage. Use with slip-on tip whenever possible. One replacement part is provided with the package. Contact nearest Field Office for additional parts, if required. For replacement and Calibration Procedure, refer to page 3 and 4 of manual. (P/N 307-0330-00 for P6056, P/N 307-0329-00 for P6057)

P6056/P6057 PROBE

CHARACTERISTICS

General Information

The P6056 (10X), and P6057 (100X), are miniature, fast-rise, low input-capacitance probes with relatively constant input resistance over a wide range of frequencies, designed for use with 50 Ω wide-band oscilloscopes such as the Tektronix 7904 with 7A19 plug-in installed.

Cable length for each probe is selected for calibrated signal delay.

These probes can also be used with sampling systems by utilizing appropriate adapters.

Both probes are equipped with a special BNC connector that provides trace identify and digital readout information when used with plug-in units or mainframes that have these features. A button on the Trace Shift Sleeve portion of the probe body provides the trace identify function.

SPECIFICATIONS

Electrical characteristics are applicable when used with an instrument that is calibrated within an ambient temperature between +20°C and +30°C. Unless otherwise stated, electrical characteristics apply over an operating temperature range from -15°C to +55°C, and to an altitude of 15,000 feet.

NOTE

The following electrical specifications apply when the probe is operating into a 50 Ω oscilloscope input or a 50 Ω termination.

Electrical

Attenuation: P6056, 10X within 3%. P6057, (Includes $\pm 2\%$ Input Resistance of Oscilloscope) 100X within 3%.

Input Resistance: P6056; 500 Ω DC to 300 MHz, (Within 3%) decreasing to 250 Ω at 1 GHz.

P6057; 5000 Ω DC to 350 MHz, decreasing to 1500 Ω at 1 GHz.

Input Capacitance: P6056 and P6057: Approximately 1 pF.

Risetime: P6056; 100 ps (probe only). P6057; 250 ps (probe only).

Bandwidth (-3 dB): P6056; DC to 3.5 GHz (probe only), DC to approximately 500 MHz with 7A19 and 7904. (Calculated from Risetime) P6057; DC to 1.4 GHz (probe only), DC to approximately 480 MHz with 7A19 and 7904.

Maximum Input Voltage: (Limited by 0.5 W nose resistor dissipation, and derated with frequency) P6056; 16 V DC or RMS (AC or pulse) to 800 MHz, decreasing to 9 V at 1 GHz. P6057; 50 V DC or RMS (AC or pulse) to 500 MHz, decreasing to 21 V at 1 GHz.

Signal Delay Time: P6056 and P6057; 8.2 ns (6 ft probe), 12.3 ns (9 ft probe), each within 35 ps.

General

Weight: 6 ft. probe-2 ounces, 9 ft. probe-3 ounces (complete with accessories, except Instruction Manual). Shipping: 6 ft. probe-12 ounces, 9 ft. probe-13 ounces.

Dimensions: Nominally 6 ft. and 9 ft. long (Calibrated for signal delay time).

Environmental: Probe will operate within specifications over the following ranges:

Temperature—From -15°C to +55°C.
Altitude—To 15,000 feet.

OPERATING INSTRUCTIONS¹

Handling

The P6056/P6057 tip is physically connected to the nose resistor. Bending, or excessive pressure on the tip may damage the resistor. Where reactive considerations permit the use of the hook tip or the bayonet ground adapter, these devices will help protect the probe tip. When the probe is not being used, the probe test tip 015-0201-00 should be installed for tip protection. Refer to the maintenance portion of this manual for nose resistor replacement information.

Soldering components to the tip can break the bond between the tip and the internal resistor. If a self-holding tip connection is required, use a pin contact taken from a small transistor socket.

Avoid kinks, sharp bends, and dents in the probe cable, as any of these can cause a reflective discontinuity in the probe response.

Probe Tip Connections

All signal and ground leads should be kept as short as possible, due to inductive effects that can cause ringing at high frequencies. A good way to make the probe connections is to touch the tip and ground sleeve directly to the appropriate points in the test circuit or through the bayonet ground adapter. When the ground connection cannot be made in this manner, attach a ground contact spring, Tektronix Part No. 214-0283-00, to the sleeve. If necessary, a short stub of wire can be soldered to the contact spring, to extend the ground connection.

If the signal originates from an instrument (such as a pulse generator) that has a coaxial output connector, use a probe-tip adapter (Tektronix Part No. 013-0084-01 for BNC; 017-0076-00 for GR) for the connection. This provides a correct environment for the signal, and eliminates noise or other external electro-magnetic interference signals.

The hook tip can be used in most measurements without adverse effects on the display, since the small series inductance it presents is insignificant except at very high frequencies. The ground-strap assembly acts as a much larger series inductor. Its effect on the display may be noticeable with pulse risetimes faster than about 0.6 or 0.7 nanosecond.

¹ Measurement Concept Booklet; Probe Measurements, Tektronix Part No. 062-1120-00 includes detailed measurement techniques.

Use with 50 Ohm Input Oscilloscopes

These probes are designed to work directly into 50 ohm wide-band oscilloscopes. No termination is necessary, and Auto Scale Factor Readout-equipped oscilloscopes will indicate the correct deflection factor for the signal that appears at the probe tip. Specifications and derating information listed will apply when the probes are used in this manner. For 50 Ω systems using other than BNC connectors, an appropriate adapter will be required between the probe connector and the system input.

Use With High-Resistance Input Oscilloscopes

The P6056 and P6057 must be terminated in 50 ohms. For oscilloscopes or plug-ins with a high resistance input, a 50 ohm termination such as the Tektronix Part No. 011-0049-01, must be attached between the probe and the oscilloscope input. (see note after "Readout and Trace Identify".)

There will be a slight signal reflection in the system appearing at 2X the cable delay time. This reflection is due to the shunt capacitance of the oscilloscope in parallel with the 50 ohm termination. To reduce the effects of this reflection, add a 2X attenuator, such as the Tektronix Part No. 011-0069-01, between the probe connector and the 50 ohm termination. This will decrease the reflection percentage by a factor of four, while increasing the attenuation by a factor of two. For sine wave measurements, the 2X attenuator is recommended to minimize standing waves.

Readout and Trace Identify

When connected to oscilloscope systems with Auto Scale Factor Readout circuitry, a resistor in the probe provides information to retain correct deflection factor readout, including probe attenuation.

NOTE

Readout and Trace Identify functions will be inoperative whenever a termination, attenuator, or adapter is inserted between the probe connector and the oscilloscope or plug-in input.

Probe Tip to GR 50 Ω Termination Adapter

This adapter, Tektronix Part Number 017-0088-00, provides a means of terminating a 50 ohm system while measuring the system voltage at the special probe tip receptacle.

Since the terminating resistor and the 50 ohm line are in parallel as seen by the probe tip, the effective source impedance for the probe will be 25 ohms.

Maximum Voltage and Power Input

The basic power rating of these probes at DC is 0.5 watt. The related DC input voltage for each probe is listed in Specifications.

Selecting the AC coupling mode in a 50 ohm oscilloscope system, or using an external coupling capacitor, will block DC current flow in the probe. When an external termination is used with a high-resistance input oscilloscope system, selecting the AC coupling mode will not block DC current flow through the termination. Use of the AC coupling mode or an external coupling capacitor will result in some sacrifice of the total system low frequency response. At high frequencies, the voltage derating listed in Specifications will apply.

The RMS voltage of a pulse signal should, if possible, be estimated before measurement. The pulse duration, duty factor, and DC level determine the RMS signal voltage. Above 500 MHz for the P6057 and 800 MHz for the P6056, the power dissipation capability of the probe is derated below 0.5 watt as indicated in Specifications "Maximum Input Voltage".

Pulse peak voltages up to 500 volts may be measured with these probes, provided the RMS probe-input voltage is no greater than the DC maximum input voltages listed in Specifications. In no case should any portion of the signal exceed the DC input rating listed in Specifications for longer than 1 millisecond.

COMPENSATION AND MAINTENANCE

General

The P6056 and P6057 consist of several subassemblies as illustrated at the back of this manual. Repair techniques are discussed at the end of this topic.

The probes are factory compensated, and normally will not require adjustment unless the setting of the compensation is disturbed. The compensation should be checked when either the probe body, nose resistor, or adjustment assembly is replaced, and whenever the adjustment has been disturbed.

Compensation equalizes the high and low frequency probe attenuation factors. This is accomplished by passing a fast-rise, flat-top pulse through the probe from a low-impedance source, and adjusting the C_{in} so an oscilloscope display indicates proper probe response.

The following list of equipment or its equivalent is required to perform accurate compensation. Specifications are minimum requirements, and substitute equipment must meet or exceed these minimum specifications. All

equipment must be in a calibrated condition and comply with rated specifications. Observe warmup requirements and operating conditions as stated in the instruction manual for each item of test equipment.

Equipment Required

1. Test oscilloscope system. Vertical deflection factor 10 mV/division at 500 MHz, sweep time 5 ns/division. Tektronix 7904 with a 7A19 and a 7B92 plug-in or equivalent.
2. Pulse Generator. Pulse risetime 0.25 ns, amplitude 10 volts peak, duration approximately 10 ns. Tektronix Type 109 or equivalent.
3. Charge network or charge line. 5 ns, 50 Ω . Tektronix 017-0067-00 network or 017-0502-00 cable. (Both items included as standard accessory with Type 109.)
4. Attenuator. 50 Ω 10X, GR. Tektronix 017-0078-00 or equivalent. (One required for P6056, two required for P6057).
5. Cable, connecting. GR 5 ns, Tektronix 017-0502-00. (Included as standard accessory with Type 109.)
6. Adapter, Probe Tip to GR, 50 Ω Terminating. Tektronix 017-0088-00.
7. Adapter, GR-to-BNC male. Tektronix 017-0064-00.

Compensation Procedure

1. Connect the equipment as shown in Fig. 2A.
2. Set the test oscilloscope Volts/Div to 10 mV, and Time/Div to 1 ns.
3. Adjust the pulse generator to produce 5 divisions of oscilloscope deflection (about 1 volt of generator output for the P6056, and 10 volts for the P6057). Adjust the oscilloscope triggering controls for a stable display.
4. Note this display carefully, as it will be the reference for proper probe compensation.
5. Remove the cable, attenuator(s), and adapter from the pulse generator and oscilloscope (leave the charge network or line connected to the 109).
6. Connect the probe and Probe Tip to GR 50 Ω Terminating Adapter as shown in Fig. 2B.
7. Compare the leading edge and front corner of the signal display with the waveform obtained in step 4.

P6056/P6057 Probe

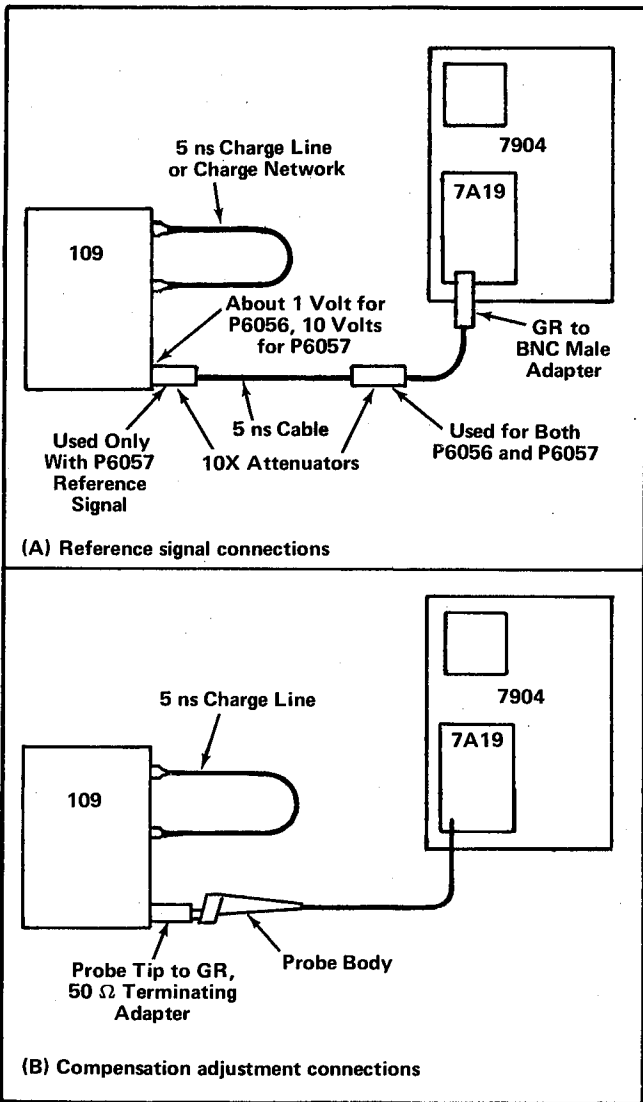

Fig. 2. Equipment setup for compensating the P6056 and P6057

8. If step 7 shows that compensation is required, proceed as follows:

- a. Grasp the Trace shift sleeve and hold it stationary while rotating the front Probe Body in a clockwise (as viewed from rear of probe) direction to unlock the compensation.
- b. Connect the probe to the 109 through the adapter as in step 7.
- c. Rotate the front body assembly either direction as necessary to match the waveform obtained in step 4 (back the Trace Shift Sleeve away from the front Probe Body if necessary to achieve more range).
- d. When the closest possible match to the waveform of step 4 has been obtained, carefully hold the front Probe Body assembly stationary while rotating the Trace Shift Sleeve in a clockwise (viewed from rear) direction to lock the compensation.

Maintenance

Refer to the Mechanical Parts List and exploded view at the back of this manual.

Fig. 3 illustrates nose resistor (item 5) replacement procedure. The plastic pressure nut (item 6) may be damaged if subjected to excessive torque. Tighten only enough for a snug fit against the resistor.

Cable length is critical. Do not shorten it as delay time specification will be altered.

Unless otherwise noted, parts that are separately listed in the Mechanical Parts List may be replaced individually.

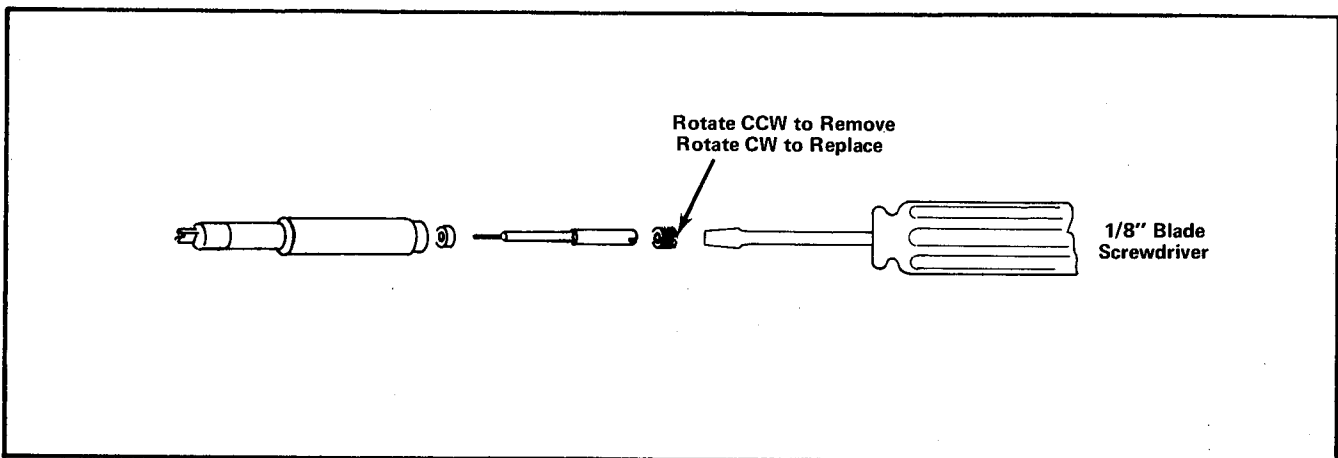
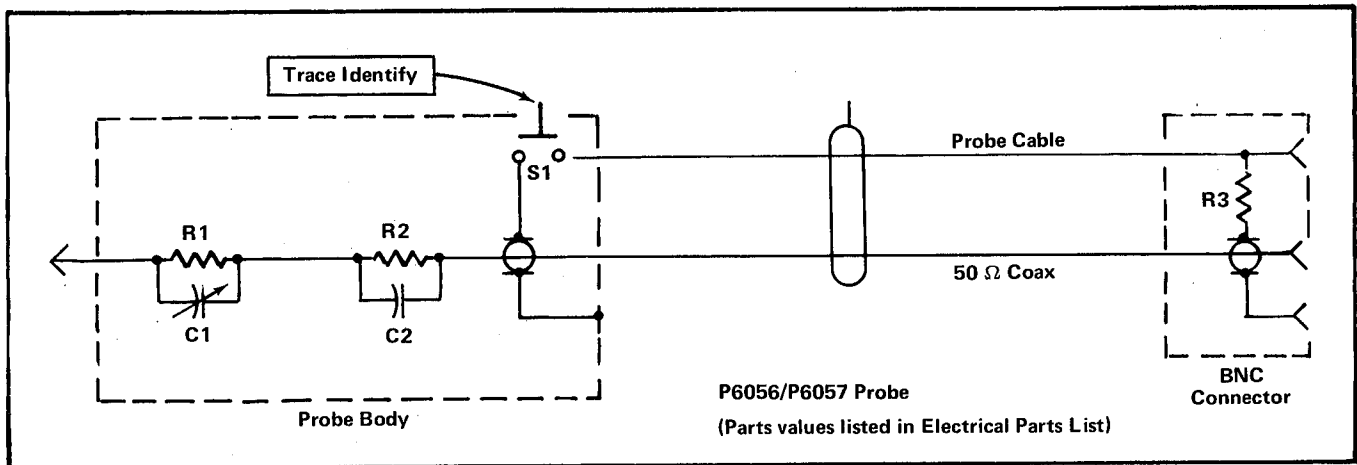

Fig. 3. P6056 and P6057 Nose Resistor Replacement.



ELECTRICAL PARTS LIST

Ckt. No.	Tektronix Part No.	Serial/Model No. Eff	Disc	Description
				P6056
CAPACITORS				
C2	283-0281-00			50 pF, Cer, 50 V, 10%
RESISTORS				
R1	307-0330-00			400 Ω , 1/2 W, 1%
R2	321-0751-06			50 Ω , 1/8 W, 1/4%
R3	317-0113-00			11 k Ω , 1/8 W, 5%
				P6057
CAPACITORS				
C2	283-0281-00			50 pF, Cer, 50 V, 10%
RESISTORS				
R1	307-0329-00			4.9 k Ω , 1/2 W, 1%
R2	321-0751-06			50 Ω , 1/8 W, 1/4%
R3	317-0682-00			6.8 k Ω , 1/8 W, 5%

NOTE

Cable and probe lengths are critical. Replacement components should match original lengths to retain performance characteristics.

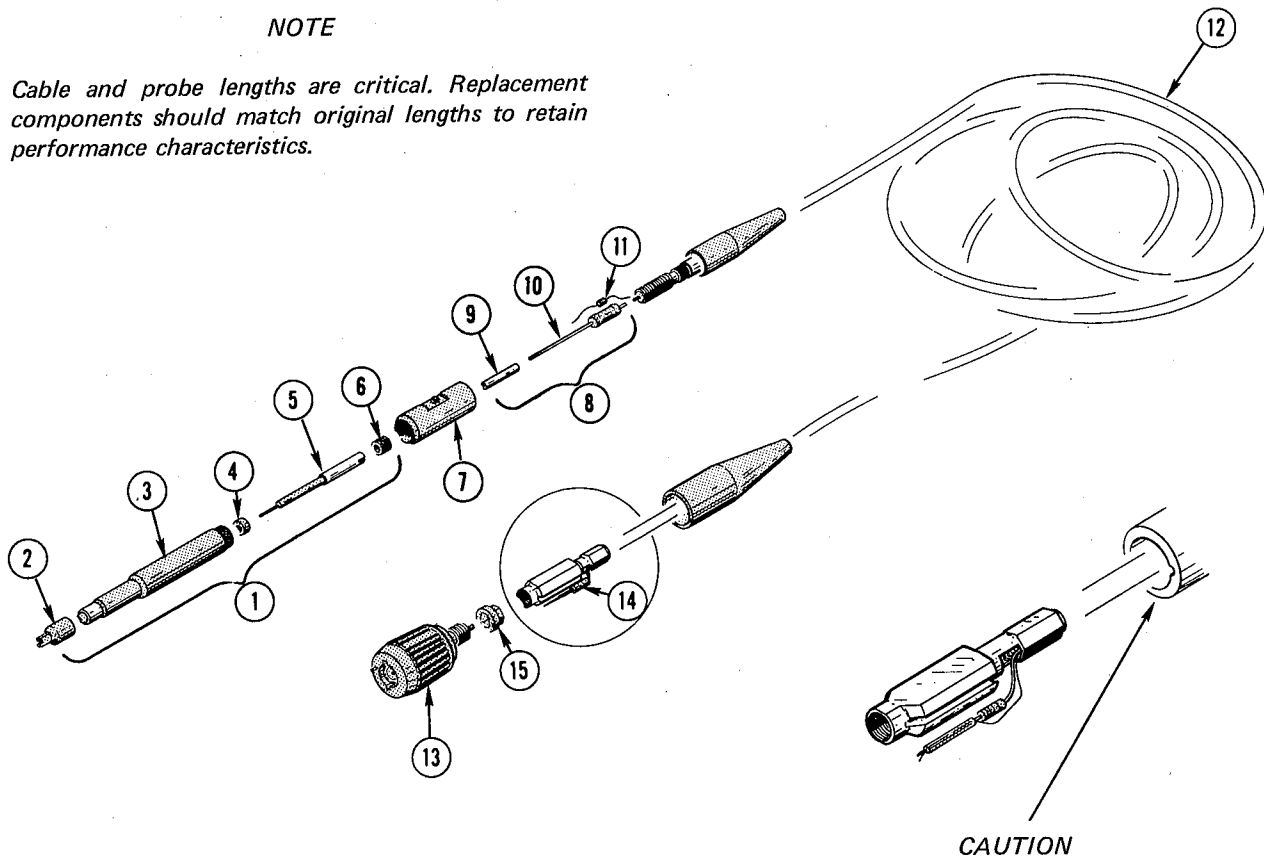

CAUTION
Observe the keyway orientation for the Cable Nipple. Improper orientation may damage associated parts.

MECHANICAL PARTS LIST

Fig. & Index No.	Tektronix Part No.	Serial/Model No. Eff	Disc	Q †	y					Description	
					1	2	3	4	5		
	010-6056-02			1						1	PROBE, P6056, 6 foot
	010-6056-04			1						1	PROBE, P6056, 9 foot
	010-6057-02			1						1	PROBE, P6057, 6 foot
	010-6057-04			1						1	PROBE, P6057, 9 foot
	- - - - -			-							probe includes:
-1	204-0514-00			1							BODY-RESISTOR ASSEMBLY
	204-0513-00			1							BODY-RESISTOR ASSEMBLY
	- - - - -			-							body-resistor assembly includes:
-2	015-0201-00			1							PROBE TIP
-3	204-0507-00			1							BODY ASSEMBLY
	204-0508-00			1							BODY ASSEMBLY
-4	166-0292-00			1							SLEEVE, support, plastic
-5	- - - - -			1							RESISTOR ASSEMBLY (See Electrical List) R1
	- - - - -			1							RESISTOR ASSEMBLY (See Electrical List) R1

¹P6056 only (See maintenance section for replacement information.)
²P6057 only (See maintenance section for replacement information.)

(A)

(B)

Fig. & Index No.	Tektronix Part No.	Serial/Model No.		Q † y	1	2	3	4	5	Description
		Eff	Disc							
-6	213-0111-00			1						SCREW, support, contact, 10-32 x 0.156 inch long
-7	166-0540-00			1						SLEEVE, trace shift, w/button
	166-0542-00			1						SLEEVE, trace shift, w/button
-8	206-0195-00			1						ATTENUATOR SUBASSEMBLY
	-----			-						attenuator subassembly includes:
-9	131-1168-00			1						CONTACT, electrical, center conductor
-10	-----			1						RESISTOR (See Electrical List) R2
-11	-----			1						CAPACITOR (See Electrical List) C2
-12	175-1320-00			1						CABLE ASSEMBLY, 6 foot
	175-1323-00			1						CABLE ASSEMBLY, 9 foot
	175-1319-00			1						CABLE ASSEMBLY, 6 foot
	175-1324-00			1						CABLE ASSEMBLY, 9 foot
-13	131-1070-00			1						CONNECTOR, electrical, BNC, w/readout contact
-14	-----			1						RESISTOR (See Electrical List) R3
	-----			1						RESISTOR (See Electrical List) R3
-15	342-0112-00			1						INSULATOR, bushing
	220-0572-00			1						NUT, hex., 10-32 x 0.25 inch
	070-1224-00			1						MANUAL, instruction (not shown)

¹P6056 only.
²P6057 only.